

A500 TG

User's Manual
Benutzerhandbuch
Mode d'emploi
Manual del usuario
Manuale dell'utente
Manual do Utilizador
安裝說明書
用戶手冊
ユーザーズマニュアル
Руководство пользователя
kullanıcı elkitabı
(EEE Yönetmeliğine Uygundur)
คู่มือการใช้



© 2018 Thermaltake Technology Co., Ltd. All Rights Reserved. 2018.07
All other registered trademarks belong to their respective companies. www.thermaltake.com



TT Premium



TT Premium

To continue achieving the corporate mission of delivering the perfect user experience, Thermaltake developed "TT Premium" with the essence of combining supreme quality products with a new logo design. TT Premium is far more than just a guarantee of quality. Behind the name, it represents the passion in DIY, Modding and Thermaltake's desire to be the most innovative brand in the PC hardware market. To satisfy the demand of the high-end PC users, TT Premium follows its core values of Excellent Quality, Unique Design, Diverse Combinations and Boundless Creativity to provide a high performance PC product for every enthusiast. <http://ttpremium.com>

Tt LCS-Liquid Cooling Support Certification



Tt LCS Certified is a Thermaltake exclusive certification applied to only products that pass the design and hardcore enthusiasts standards that a true LCS chassis should be held to. The Tt LCS certification was created so that we at Thermaltake can designate to all power users which chassis have been tested to be best compatible with extreme liquid cooling configurations to ensure you get the best performance from the best features and fitment.

Join Tt Community To Receive Benefits



Dear Valued Customer,

Thank you for choosing Thermaltake.

As a new user we value your thoughts and opinions and your feedback is important to us. We at Thermaltake would like to use this opportunity to invite you to join our Community Forums. Register today to start enjoying the full benefits of our community.



Benefits of being a member:

- Quick and responsive user support
- Receive help and advice with new builds
- Keep up to date with new product releases
- Share your thoughts and builds with the community
- Enter monthly contests and giveaways

Brand official website

<http://www.thermaltake.com/>

Global Facebook

<https://www.facebook.com/ThermaltakeInc>

Taiwan Facebook

<http://www.facebook.com/ThermaltakeTW>

Global community forums

<http://community.thermaltake.com>

CONTENTS

Chapter 1. Product Introduction

1.0	Specification	01
1.1	Accessory	01
1.2	Warning and Notice	02

Chapter 2. Installation Guide

2.0	Side Panels Disassembly	04
2.1	Power Supply Unit (PSU) Installation	05
2.2	Motherboard Installation	06
2.3	3.5" & 2.5" HDD Installation	07
2.4	PCI Card Installation	09
2.5	Air Cooling Installation	10
2.6	Liquid Cooling Installation	11





Chapter3 Leads Installation Guide

3.0	Case LED connection	13
3.1	USB 3.0 connection	13
3.2	USB 3.1 connection	13
3.3	Audio connection	13
3.4	Thermaltake Power Supply Series (Optional)	19
3.5	Tt RGB Plus Ecosystem	20

Specification

Case Type	Mid Tower
Dimension (H*W*D)	560 x 236 x 510 mm (22 x 9.3 x 20.1 inch)
Side Panel	4mm Tempered Glass x 2 (Left & Right)
Cooling System	Rear (exhaust) : 120 x 120 x 25 mm fan (1000rpm, 22dBA) x 1 Front (intake) : 120 x 120 x 25 mm fan (1000rpm, 22dBA) x 2
Drive Bays - Accessible - Hidden	2.5" or 3.5" x 4 (HDD Cage) 2.5" or 3.5" x 2 (HDD Cage); 2.5" x 1 (HDD Bracket)
Expansion Slots	8 + 2
Motherboards	6.7" x 6.7" (Mini ITX), 9.6" x 9.6" (Micro ATX), 12" x 9.6" (ATX)
Fan Support	Front: 3 x 120mm, 3 x 140mm Top: 3 x 120mm, 2 x 140mm Rear: 1 x 120mm
Radiator Support	Front: 1 x 360mm, 1 x 420mm Top: 1 x 360mm, 1 x 280mm Rear: 1 x 120mm
Clearance	CPU cooler height limitation: 160mm VGA length limitation: 295mm (with HDD rack) 420mm (without HDD rack) PSU length limitation: 220mm

Accessory

Figure	Parts Name	Q'ty	Used for
	Screw M3 x 5mm	12	Motherboard
	Screw M3 x 5mm	28	2.5" SSD
	Screw M3 x 5mm	4	2.5" SSD
	HDD / SSD Rubber	4	2.5" SSD
	Screw #6-32 x 6mm	4	Power
	Screw T5 x 12mm	12	Case Fan
	Screw #6-32 x 28mm	12	Case Fan
	Stand-off #6-32 x 6mm	3	Motherboard
	Cable Tie	10	Cable Management
	Buzzer	1	Motherboard Alarm

Warning and Notice

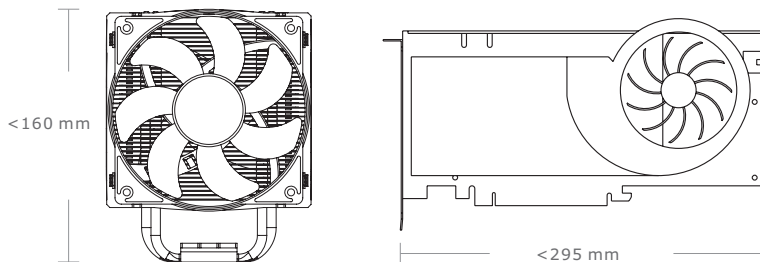

Warning!!

CPU Cooler Height Limitation:

Please ensure that your CPU cooler does NOT exceed 160mm (6.3 inches) height.

VGA (Add-on card) Length Limitation:

Please ensure that your VGA (Add-on card) does NOT exceed 295mm (11.6 inches) length.

Warnung!!

CPU-Kühler Höhenbeschränkung:

Bitte stellen Sie sicher, dass Ihr CPU-Kühler 160 mm (6,3 Zoll) Höhe nicht überschreitet.

VGA (Add-on-Karte) Längenbeschränkung:

Bitte stellen Sie sicher, dass Ihre VGA (Add-on-Karte) 295 mm (11,6 Zoll) Länge nicht überschreitet.

Avertissement !

Limite de hauteur du ventilateur de CPU :

Vérifiez que la hauteur du ventilateur de CPU ne dépasse pas 160 mm.

Limite de longueur de la carte (complémentaire) VGA :

Vérifiez que la longueur de votre carte (complémentaire) VGA ne dépasse pas 295 mm

Precaución

Limitación de altura del refrigerador de CPU:

Asegúrese de que la altura de su refrigerador de CPU no excede los 160 mm (6,3 pulgadas).

Limitación de longitud de la tarjeta de vídeo (adicional):

Asegúrese de que la longitud de su tarjeta de vídeo (adicional) no excede los 295 mm (11,6 pulgadas).

Attenzione!

Limitazione altezza dissipatore CPU:

Assicurarsi che l'altezza del dissipatore CPU NON superi 160 mm (6,3 pollici).

Limitazione lunghezza VGA (scheda aggiuntiva):

Assicurarsi che la lunghezza del VGA (scheda aggiuntiva) NON superi 295 mm (11,6 pollici).

Atenção!!

Limite de altura para o dissipador do CPU:

O limite de altura para o dissipador do CPU é 160 mm (6,3 polegadas).

Limite de comprimento para VGA (placa gráfica):

O limite de comprimento para VGA (placa gráfica) é 295 mm (11.6 polegadas).

警告 !!

CPU 冷却器的高度限制：

請確保 CPU 冷却器的高度不超過 160 mm (6.3 英寸)。

VGA (附加介面卡) 的長度限制：

請確保 VGA (附加介面卡) 的長度不超過 295 mm (11.6 英寸)。

警告 !!

CPU 散热器高度限制：

请确保 CPU 散热器的高度不超过 160 mm (6.3 英寸) 。

VGA (附加卡) 长度限制：

请确保 VGA (附加卡) 的长度不超过 295 mm (11.6 英寸) 。

警告

CPUクーラーの高さ制限:

CPUクーラーの高さが160mmを超えていないことを確認してください。

VGA (アドオンカード) の長さ制限:

VGA (アドオンカード) の長さが295mmを超えていないことを確認してください。

Внимание!

Ограничение по высоте охладителя ЦП

Убедитесь, что высота охладителя ЦП (центрального процессора) НЕ превышает 160 м (6,3 дюйма).

Ограничение по длине видеокарты VGA (плата расширения)

Убедитесь, что длина видеокарты VGA (плата расширения) НЕ превышает 295 мм (11,6 дюйма).

Uyarı!!

CPU Soğutucu Yükseklik Sınırlaması:

Lütfen CPU soğutucunuzun yüksekliğinin 160mm'yi (6,3 inç) GEÇMEDİĞİNDEN emin olun.

VGA (Eklenli kart) Uzunluk Sınırlaması:

Lütfen VGA'nızın (Eklenli kart) uzunluğunun 295mm'yi (11,6 inç) GEÇMEDİĞİNDEN emin olun.

คำเตือน!!

ขีดจำกัดความสูงสำหรับซีพียูของ CPU:

ขีดจำกัดความสูงสำหรับซีพียูของ CPU คือ 160 มม. (6.3 นิ้ว)

ขีดจำกัดความยาวสำหรับ VGA (การ์ดแสดงผล):

ขีดจำกัดความยาวสำหรับ VGA (การ์ดแสดงผล) คือ 295 มม. (11.6 นิ้ว)

Side Panels Disassembly

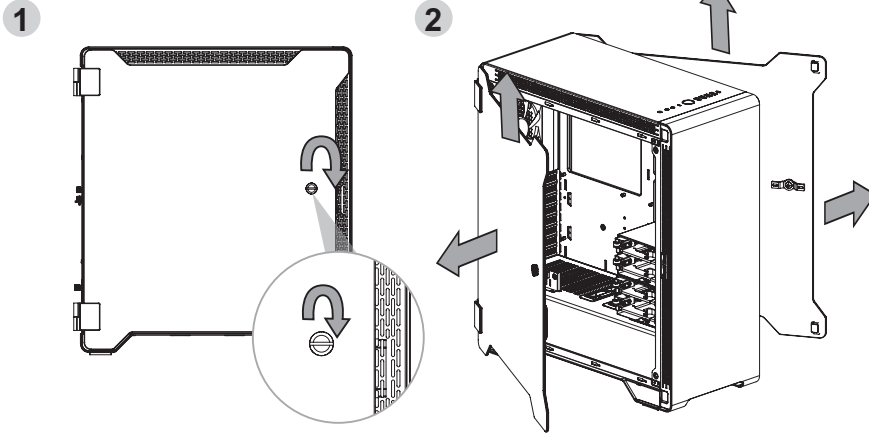

English /
Remove the screws on the back of the chassis,
and open the side panel

Deutsch /
Entfernen Sie die Schrauben auf der Rückseite
des Gehäuses und öffnen Sie das Seitenteil

Français /
Enlevez les vis à l'arrière du châssis et ouvrez le
panneau latéral

Español /
Extraiga los tornillos de la parte posterior de la
caja y abra el panel lateral

Italiano /
Rimuovere le viti sulla parte posteriore dello
chassis e aprire il pannello laterale

Português /
Remova os parafusos na parte de trás da caixa e
abra o painel lateral

繁體中文 /
移除機殼後方螺絲，將側窗打開

简体中文 /
卸除机壳后方螺丝，将侧窗打开

日本語 /
シャーシ背面のねじを取り外し、サイドパネ
ルを開きます

Русский /
Открутите винты на задней стенке корпуса
и откройте боковую панель

Türkçe /
Kasanın arkasındaki vidaları çıkarın ve yan
paneli açın

ภาษาไทย /
ถอดสกรูที่ด้านหลังของแชสซีส์
แล้วเปิดแผงด้านข้าง

Power Supply Unit (PSU) Installation

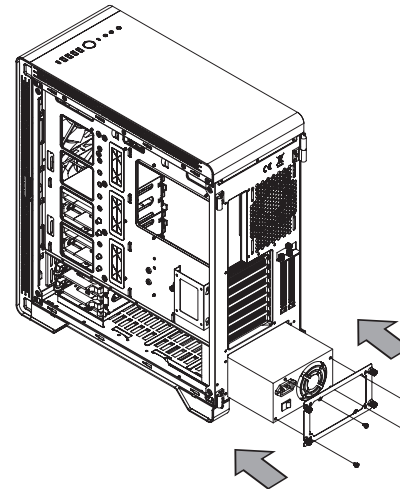

English /
Place the PSU in proper location.

Deutsch /
Platzieren Sie das Netzteil in der richtigen Position.

Français /
Placez l'alimentation dans la position appropriée.

Español /
Instale la PSU en la ubicación correcta.

Italiano /
Posizionare la PSU in modo corretto.

Português /
Coloque o PSU na sua devida posição.

繁體中文 /
將電源供應器放在正確的位置

简体中文 /
将电源供应器放在正确的位置

日本語 /
PSUを適切な口ケーションに取り付けます。

Русский /
Установите блок питания в надлежащее место.

Türkçe /
PSU'yu, uygun konuma yerleştirin.

ภาษาไทย /
วาง PSU ในตำแหน่งที่เหมาะสม

Motherboard Installation

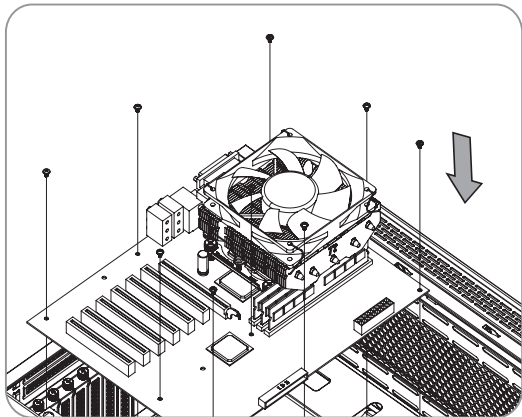

English /

1. Lay down the chassis.
2. Install the motherboard in proper location and secure it with screws.

Deutsch /

1. Legen Sie das Gehäuse auf die Seite.
2. Installieren Sie die Hauptplatine in ihrer vorgesehenen Position und sichern Sie sie mit Schrauben.

Français /

1. Posez à plat le châssis.
2. Installez la carte mère dans l'endroit approprié et sécurisez-la avec des vis.

Español /

1. Tumbé el chasis.
2. Instale la placa madre en la ubicación adecuada y asegúrela con tornillos.

Italiano /

1. Poggiare lo chassis.
2. Installare la scheda madre nella posizione appropriata e fissarla con le viti.

Português /

1. Deixe a caixa.
2. Instale a motherboard no local adequado e aparafuse.

繁體中文 /

1. 將機殼平放。
2. 將主機板放置在合適的位置並用零件包中之螺絲固定。

简体中文 /

1. 放平机箱。
2. 在合适的位置安装主板并以螺丝安全固定。

日本語 /

1. シャーシを下に置きます。
2. マザーボードを適切な場所に取り付け、ねじで固定します。

Русский /

1. Раскройте системный блок.
2. Установите материнскую плату в надлежащее место и закрепите ее винтами.

Türkçe /

1. Kasayı yan yatırın.
2. Ana kartı uygun konuma takın ve vidalarla sabitleyin.

ภาษาไทย /

1. วางแชสซีส์นอนลง
2. ติดตั้งเมนบอร์ดในตำแหน่งที่เหมาะสมแล้วขันสกรูยึดให้แน่น

3.5" & 2.5" HDD Installation

2.5" HDD

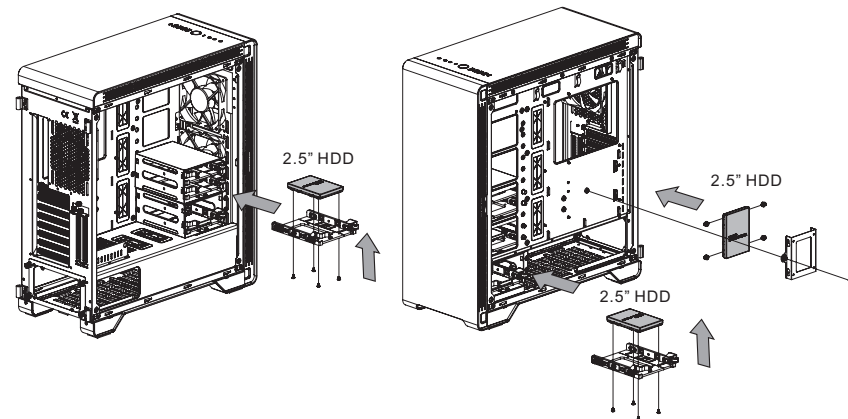

3.5" HDD

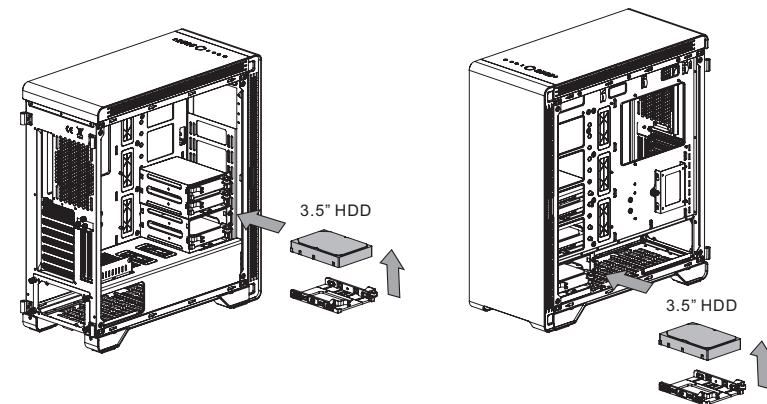

PCI Card Installation

English /

1. Pull the HDD tray out.
2. Place the 2.5" or 3.5" hard drive on the tray and secure it with screws.
3. Slide the HDD tray back to the HDD cage.

Deutsch /

1. Ziehen Sie den HD-Schacht heraus.
2. Montieren Sie die 2,5 oder 3,5 Zoll Festplatte im Schacht und sichern Sie sie mit Schrauben.
3. Schieben Sie den Schacht wieder in den Festplattenkäfig.

Français /

1. Enlevez le boîtier du disque dur.
2. Placez le disque dur de 2,5" ou de 3,5" dans le boîtier et fixez-le avec des vis.
3. Refaites glisser le boîtier du disque dur dans la cage de disques durs.

Español /

1. Extraiga la bandeja del disco duro.
2. Coloque el disco duro de 2'5 ó 3'5" en la bandeja y fíjelo con los tornillos.
3. Vuelva a meter la bandeja del disco duro en su hueco.

Italiano /

1. Estrarre il vano HDD.
2. Posizionare il disco fisso da 2,5" o 3,5" nel vano e fissarlo con le viti.
3. Fare scorrere l'HDD indietro verso la struttura a gabbia HDD.

Português /

1. Puxe a bandeja do disco rígido para fora.
2. Coloque o disco rígido de 2,5" ou 3,5" na bandeja e fixe com parafusos.
3. Deslize a bandeja do disco rígido de volta para a caixa do disco rígido.

繁體中文 /

1. 將硬碟托盤取出
2. 將2.5"或3.5"硬碟放置在硬碟托盤上，用螺絲固定硬碟
3. 將硬碟托盤放回硬碟磁架中

簡體中文 /

1. 將硬碟托盤取出
2. 將2.5"或3.5"硬碟放置在硬碟托盤上，用螺絲固定硬碟
3. 將硬碟托盤放回硬碟磁架中

日本語 /

1. HDDトレイを引き出して外します。
2. 2.5インチHDD、SSDもしくは3.5インチHDDドライブをトレイにネジで固定します。
3. HDDトレイをHDDケージに戻します。

Русский /

1. Вытяните лоток для жестких дисков.
2. Установите 2,5- или 3,5-дюймовый жесткий диск в лоток и закрепите его винтами.
3. Установите лоток для жестких дисков обратно в корпус.

Türkçe /

1. HDD tepsisini dışarı çekin.
2. 2,5" veya 3,5" sabit disk sürücüsünü tepsinin üzerine yerleştirin ve vidalarla sabitleyin.
3. HDD tepsisini HDD kafesine geri yerleştirin.

ภาษาไทย /

1. ดึงถาด HDD ออกมา
2. วางฮาร์ดดิสก์พืชนาถ 2.5" หรือ 3.5" ลงบนถาดแล้วขันสกรูยึดไฟแนน
3. เลื่อนถาด HDD กลับเข้าในโครงง HDD

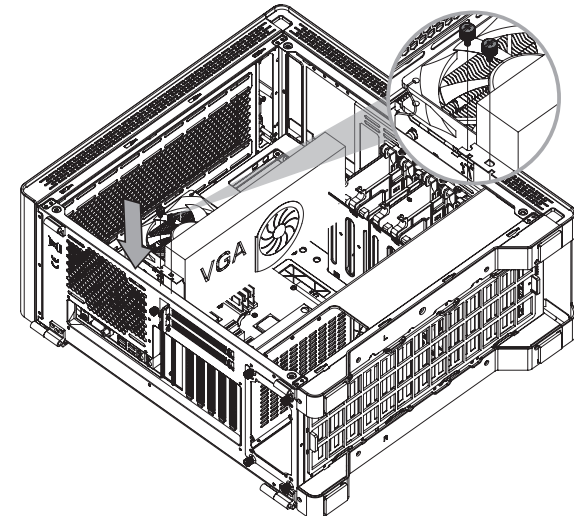
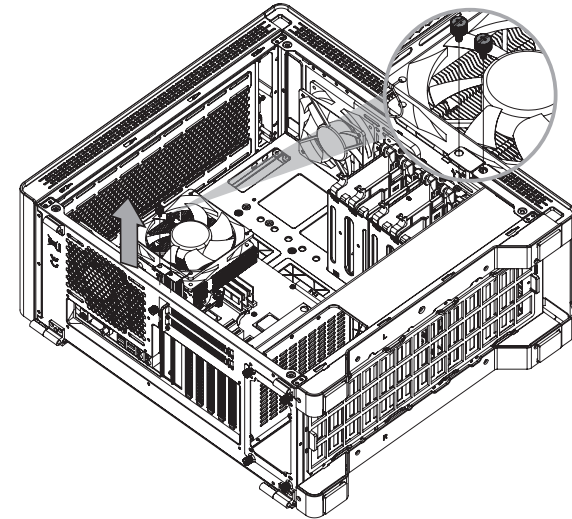

Air Cooling Installation

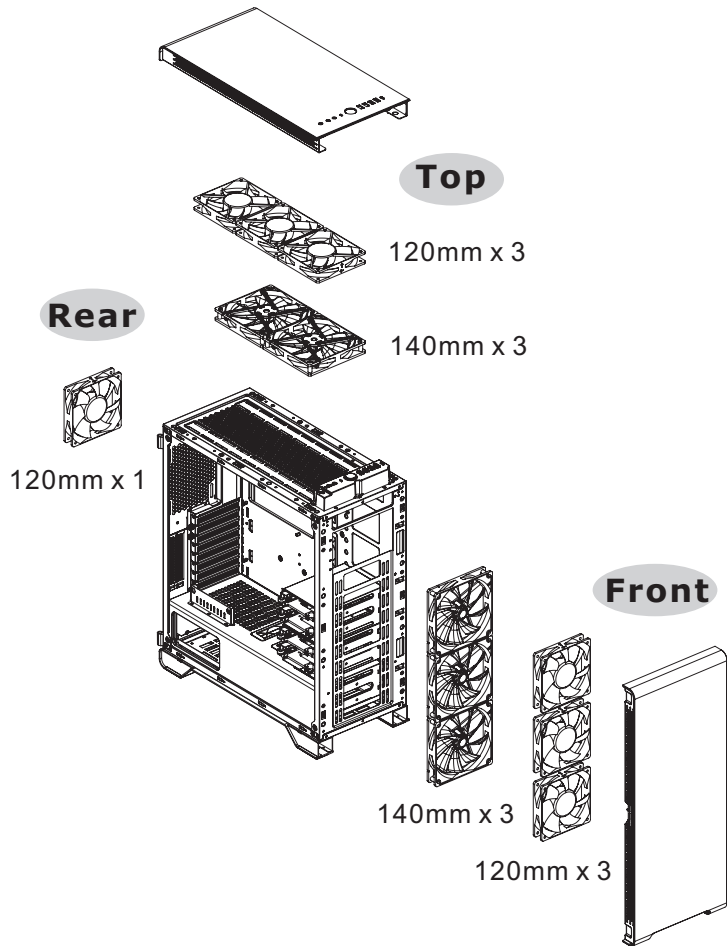

Liquid Cooling Installation

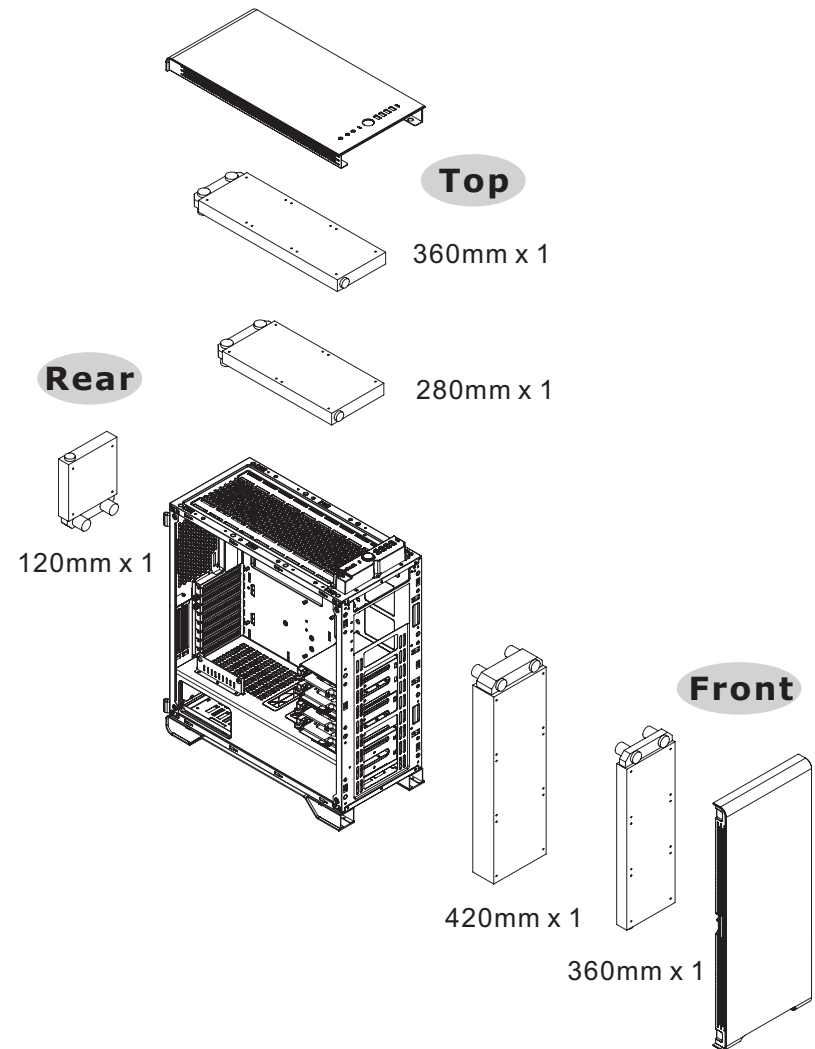

Français

Guide d'installation des fils

Connexion des voyants du boîtier / Sur la face avant du boîtier, vous trouverez plusieurs voyants et les fils des boutons. S'il vous plaît consultez le guide d'utilisateur du fabricant de votre carte mère, puis connectez ces fils aux connecteurs sur la carte mère.

Connexion USB 2.0 / S'il vous plaît consultez le manuel de votre carte mère à la section "Connexion USB"

Connexion USB 3.0 /

1. Vérifiez que votre carte mère prend en charge la connexion USB 3.0.
2. Connectez le câble USB 3.0 au port USB 3.0 disponible sur votre ordinateur.

Connexion Audio / S'il vous plaît référez vous à l'illustration suivante du connecteur audio et au guide de l'utilisateur de votre carte mère. S'il vous plaît sélectionnez une carte mère supportant AC'97 ou HD Audio (Azalia), (faites attention que votre audio supporte l'AC'97 ou HD Audio (Azalia)) sinon cela pourrait endommager votre matériel.

Español

Guía de Instalación de Cables

Conexión del LED de la caja / En la parte frontal de la caja, encontrará algunos LED y cables de interruptores. Consulte el manual del usuario del fabricante de la placa madre, a continuación conecte estos cables al conector de la placa madre.

Conexión USB 2.0 / Consulte el manual de la placa madre para obtener más información sobre el apartado "Conexión USB"

Conexión USB 3.0 /

1. Asegúrese de que la placa base admite conexión USB 3.0.
2. Conecte el cable USB 3.0 al puerto USB 3.0 disponible en el equipo.

Conexión de Audio / Consulte la siguiente ilustración del conector de Audio y el manual del usuario de la placa madre. Seleccione la placa madre que utiliza AC'97 o HD Audio (Azalia), (asegúrese de que su audio admite AC'97 o HD Audio (Azalia)) si no, sus dispositivos resultarán dañados

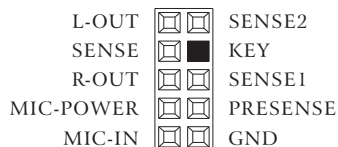

AUDIO AZALIA Function

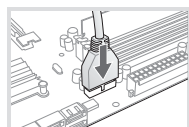

USB 3.0 Connection

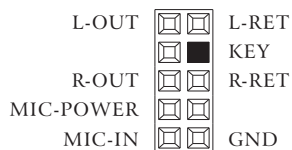

AUDIO AC'97 Function

Italiano

Guida di installazione dei contatti

Connessione del LED del case / Nella parte anteriore del case, sono presenti alcuni contatti per interruttori e LED. Consultare il manuale utente del produttore della scheda madre, quindi connettere i contatti alla parte superiore del pannello sulla scheda madre.

Connessione USB 2.0 / Consultare il manuale per la scheda madre che comprende la sezione relativa alla "connessione USB".

Connessione USB 3.0 /

1. Accertarsi che la scheda madre supporti la connessione USB 3.0.
2. Collegare il cavo USB 3.0 alla porta USB 3.0 disponibile sul computer.

Connessione Audio / Fare riferimento all'illustrazione riportata di seguito del connettore Audio e al manuale utente per la scheda madre. Selezionare la scheda madre relativa a AC'97 o HD Audio (Azalia) e considerare che il supporto audio è compatibile con AC'97 o HD Audio (Azalia); in caso contrario, le periferiche potrebbero venire danneggiate.

Português

Guia de Instalação Eléctrica

Ligação do LED da Caixa / Na parte dianteira da caixa pode encontrar alguns LEDs e fios eléctricos. Consulte o manual de utilizador do fabricante da sua motherboard e ligue os fios à parte superior do painel na motherboard.

Ligação USB 2.0 / Consulte o manual da sua motherboard para ver a secção de "Ligação USB".

Ligação USB 3.0 /

1. Certifique-se que a sua motherboard suporta ligação USB 3.0.
2. Ligue o cabo USB 3.0 à porta USB 3.0 disponível no seu computador.

Ligação Áudio / Consulte a imagem seguinte do conector Áudio e o manual de utilizador da sua motherboard.

Selecione a motherboard que utiliza AC'97 ou HD Audio (Azalia), (verifique se a sua placa de áudio suporta AC'97 ou HD Audio (Azalia)) ou irá danificar o(s) seu(s) dispositivo(s).

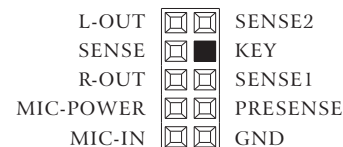

AUDIO AZALIA Function

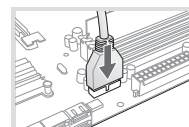

USB 3.0 Connection

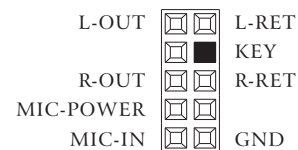

AUDIO AC'97 Function

繁體中文

線材安裝說明

機殼LED連接方式 / 在機殼前方的面板後面，可以找到一些LED與開關線材 (POWER Switch....)，請參考主機板使用說明書，並將機殼上的線材正確地連接到主機板上，這些線材通常都會印有標籤在上面，如果沒有的話，請找出機殼前方面板上線材原本的位置以知道正確的來源。

USB 2.0 連接 / 請參考主機板使用手冊找出主機板上的USB連接孔位

USB 3.0 連接 /

1. 請確認主機板是否支援USB 3.0傳輸介面。
2. 連接USB 3.0傳輸線至主機板上的USB3.0接埠。

音效連接 / 請根據下面的音源接頭圖示與主機板使用手冊來連接音效裝置，請確認主機板上的音效裝置是支援AC'97音效或是HD音效(Azalia)，裝置錯誤可能會導致主機板音效裝置的毀損，某些主機板的音效裝置不會與下方的圖示完全相同，請參酌主機板使用手冊以得到正確的安裝資訊

简体中文

线材安装说明

机壳LED连接方式 / 在机壳前方的面板后面，可以找到一些LED与开关线材 (POWER Switch....)，请参考主板使用说明书，并将机壳上的线材正确地连接到主板上，这些线材通常会印有标签在上面，如果没有的话，请找出机壳前方面板上线材原本的位置以知道正确的来源。

USB 2.0 连接 / 请参考主板使用手册找出主板上的USB连接孔位

USB 3.0 连接 /

1. 请确认主板是否支持USB 3.0传输接口。
2. 连接USB 3.0传输线至主板上的USB3.0接埠。

音效连接 / 请根据下面的音源接头图示与主板使用手册来连接音效装置，请确认主板上的音效装置是支持AC'97音效或是HD音效(Azalia)，装置错误可能会导致主板音效装置的毁损，某些主板的音效装置不会与下方的图标完全相同，请参酌主板使用手册以得到正确的安装信息

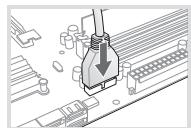
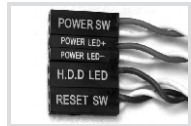

USB 3.0 Connection

L-OUT		SENSE2
SENSE		KEY
R-OUT		SENSE1
MIC-POWER		PRESENSE
MIC-IN		GND

AUDIO AZALIA Function

L-OUT		L-RET
		KEY
R-OUT		R-RET
MIC-POWER		
MIC-IN		GND

AUDIO AC'97 Function

L-OUT		SENSE2
SENSE		KEY
R-OUT		SENSE1
MIC-POWER		PRESENSE
MIC-IN		GND

AUDIO AZALIA Function

L-OUT		L-RET
		KEY
R-OUT		R-RET
MIC-POWER		
MIC-IN		GND

AUDIO AC'97 Function

日本語

リード線の取り付けガイド

ケース LED の接続 / ケース前面には、LEDとスイッチリード線があります。マザーボードメーカーのユーザーマニュアルを参照し、これらのリード線をマザーボードのパネルヘッダに接続してください。

USB 2.0 の接続 / マザーボードのマニュアルを参照して、「USB接続」のセクションを探します。

USB 3.0 の接続 /

1. お使いのマザーボードがUSB 3.0接続をサポートしていることを確認してください。
2. USB 3.0ケーブルをコンピュータの空いているUSB 3.0ポートに接続します。

オーディオ接続 / オーディオコネクタの次の図とマザーボードのユーザーマニュアルを参照してください。AC'97またはHDオーディオ(Azalia)を使用するマザーボードを選択してください(オーディオがAC'97またはHDオーディオ(Azalia)をサポートしていることを確認してください)。サポートしていないと、デバイスが損傷します。

Русский

Указания по прокладке кабелей

Подключение индикаторов корпуса / В передней части корпуса расположены индикаторы и провода выключателей. Перед подсоединением этих проводов к монтажной колодке панели на материнской плате изучите руководство пользователя производителя материнской платы.

Подключение USB 2.0 / См. раздел «Подключение USB» в руководстве материнской платы.

Подключение USB 3.0 /

1. Убедитесь, что материнская плата поддерживает подключение по стандарту USB 3.0.
2. Подсоедините кабель USB 3.0 к свободному порту USB 3.0 компьютера.

Подключение аудиоразъема / См. следующую иллюстрацию аудиоразъема и руководство пользователя материнской платы. Выберите материнскую плату, в которой используется кодек AC'97 или HD Audio (Azalia) (убедитесь, что звуковая плата поддерживает кодек AC'97 или HD Audio (Azalia)). В противном случае можно повредить устройства.

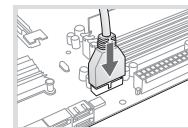
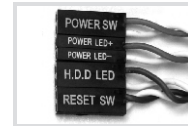

USB 3.0 Connection

L-OUT		SENSE2
SENSE		KEY
R-OUT		SENSE1
MIC-POWER		PRESENSE
MIC-IN		GND

AUDIO AZALIA Function

L-OUT		L-RET
		KEY
R-OUT		R-RET
MIC-POWER		
MIC-IN		GND

AUDIO AC'97 Function

Türkçe

Ara Kablo Kurulum Kılavuzu

Kasa ışık bağlantısı / Kasanın ön kısmında bazı ışıklar ve anahtar ara kabloları görebilirsiniz. Lütfen anakart üreticinizin sağladığı kullanım kılavuzuna bakın ve daha sonra, bu ara kabloları, anakart üzerindeki panel bağlantı noktalarına bağlayın. USB 2.0 bağlantısı / Lütfen anakart kılavuzunuzun "USB bağlantısı" bölümüne bakın.

USB 3.0 Bağlantısı /

1. Ana kartınızın USB 3.0 bağlantısını desteklediğinden emin olun.
 2. USB 3.0 kablo sunu, bilgisayarınızdaki kullanılabilir USB 3.0 bağlantı noktasına bağlayın.
- Ses Bağlantısı / Lütfen aşağıdaki Ses konektörü resmine ve anakartınızın kullanım kılavuzuna bakın. Lütfen AC'97 veya HD Audio(Azalia) spesifikasyonunu kullanan bir anakart seçin (ses sisteminizin AC'97 veya HD Audio (Azalia) spesifikasyonunu desteklediğini unutmayın); aksi takdirde, aygıt(lar)ınız zarar görür.

ภาษาไทย

คู่มือการติดตั้งสายไฟ

การเชื่อมต่อไฟ LED ของเคส / ที่ด้านหน้าของเคส คุณจะเห็นไฟ LED และสายไฟของสวิตซ์ กรณีศึกษาสายละเอียดจากคู่มือผู้ใช้ของผู้ผลิตแผงวงจรหลักของคุณ จากนั้นให้เชื่อมต่อสายไฟเหล่านี้เข้ากับส่วนหัวของแผงบนแผงวงจรหลัก

การเชื่อมต่อ USB 2.0 / กรุณาศึกษารายละเอียดจากคู่มือผู้ใช้ของผู้ผลิตแผงวงจรหลักของคุณ ในหัวข้อ "การเชื่อมต่อ USB"

การเชื่อมต่อ USB 3.0 /

1. ตรวจสอบให้แน่ใจว่าแผงวงจรหลักของคุณรองรับการเชื่อมต่อ USB 3.0
 2. เชื่อมต่อสาย USB 3.0 เข้ากับพอร์ต USB 3.0 ที่สามารถใช้งานได้นบนคอมพิวเตอร์ของคุณ
- การเชื่อมต่ออุปกรณ์รับส่งสัญญาณเสียง/ กรุณาตรวจสอบรายละเอียดจากภาพประกอบของตัวเชื่อมต่อสัญญาณเสียงต่อไป และคู่มือผู้ใช้ของผู้ผลิตแผงวงจรหลักของคุณ
- กรุณาเลือกแผงวงจรหลักที่ใช้ AC'97 หรือ HD Audio(Azalia)
(กรุณาตรวจสอบให้แน่ใจว่าอุปกรณ์รับส่งสัญญาณเสียงของคุณรองรับ AC'97 หรือ HD Audio (Azalia)) มิฉะนั้นอุปกรณ์ของคุณอาจเสียหายได้

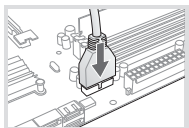
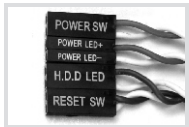

USB 3.0 Connection

L-OUT		SENSE2
SENSE		KEY
R-OUT		SENSE1
MIC-POWER		PRESENSE
MIC-IN		GND

AUDIO AZALIA Function

L-OUT		L-RET
		KEY
R-OUT		R-RET
MIC-POWER		
MIC-IN		GND

AUDIO AC'97 Function

Thermaltake Power Supply Series (Optional)



What is Smart Power Management (SPM)?

Smart Power Management (SPM) is a cloud-based software that seamlessly integrates three intelligent platforms – DPS G PC APP 3.0, DPS G Smart Power Management Cloud 1.0 and DPS G Mobile APP 1.0 – and compiles key statistics about your PC into detailed charts and breakdowns for your instant PC status view and management. With easy access to SPM through your PC or mobile devices, whether you are outside or indoors, enjoy taking full control of your build anytime, anywhere!



Thermaltake has several power supply product lines; please refer to our official website and Facebook Fan Page for more detail information!

Brand official website:

<http://www.thermaltake.com/>

Global Facebook :

<https://www.facebook.com/ThermaltakeInc>

Taiwan Facebook

<https://www.facebook.com/ThermaltakeTW>



Learn more about SPM

